

*Alle Instrumente auch in 33 cm Länge erhältlich, siehe Kapitel 1, ab Seite 17*  
*All Instruments also in the length of 33 cm available, see chapter 1, page 17*

Seite  
Page

<b>Dreh- und zerlegbare Instrumente</b> Rotating and Detachable Instruments		<b>2-5</b>
<b>Trokarhülsen, Trokare</b> Trocarsleeves, Trocars	LAP, Kapitel 1 LAP, chapter 1	<b>4-6</b>
<b>Reduzierhülsen, Dilatationssätze, LAP-Zubehör</b> Reducer Sleeves, Dilation Set, LAP-Accessories	LAP, Kapitel 1 LAP, chapter 1	<b>7</b>
<b>Autoklavierbare Laparoscope</b> Autoclavable Laparoscopes	LAP, Kapitel 1 LAP, chapter 1	<b>8</b>
<b>Fiberlichtleitkabel</b> Fiber Light cables	LAP, Kapitel 1 LAP, chapter 1	<b>9</b>
<b>Hakenelektroden</b> Hook-tip electrodes	LAP, Kapitel 1 LAP, chapter 1	<b>10-13</b>
<b>Saug- und Spülkanülen</b> Suction and Irrigation Tubes	LAP, Kapitel 1 LAP, chapter 1	<b>14-15</b>
<b>Zubehör für Laparoskopie</b> Accessories for Laparoscopy	LAP, Kapitel 1 LAP, chapter 1	<b>16</b>
<b>Dreh- und zerlegbare Instrumente</b> Rotating and Detachable Instruments	LAP, Kapitel 1 LAP, chapter 1	<b>17-33</b>
<b>Endo-Haken-System</b> Endo-Hook-System	LAP, Kapitel 1 LAP, chapter 1	<b>34-39</b>
<b>Reinigung und Pflege</b> Care and Cleaning	LAP, Kapitel 1 LAP, chapter 1	<b>40</b>
<b>Handgriffe</b> Handles	LAP, Kapitel 1 LAP, chapter 1	<b>41</b>
<b>Zerlegbare Zangen (Bipolar)</b> Detachable Forceps (Bipolar)	LAP, Kapitel 1 LAP, chapter 1	<b>45-46</b>
<b>Faßzangen mit Federgriff</b> Graspers with Spring-Handle	LAP, Kapitel 1 LAP, chapter 1	<b>47</b>





Trocarhülsen mit Trompetenventil und Hahn

Trocar sleeves with trumpet valve and stopcock

∅ 5,0 mm	29-00505	∅ 10,5 mm	29-00509
∅ 5,5 mm	29-00506	∅ 11,0 mm	29-00511
∅ 10,0 mm	29-00510	∅ 12,5 mm	29-00512



Reduzierstück PPSU

Reducer PPSU

∅ 10,0 mm - 5,5 mm	29-00568
∅ 11,0 mm - 5,5 mm	29-00569
∅ 12,5 mm - 10,0 mm	29-00570
∅ 12,5 mm - 5,5 mm	29-00571



Trokare mit Dreikant-Spitze, passend für  
Metall- und Kunststoff-Trocarhülsen

Trocars with three-edged tip, suitable for  
metal- and plastic-trocar sleeves

∅ 5,0 mm	29-01505	∅ 10,5 mm	29-01509
∅ 5,5 mm	29-01506	∅ 11,0 mm	29-01511
∅ 10,0 mm	29-01510	∅ 12,5 mm	29-01513



Trokare mit Kegel-Spitze

Trocars with conical tip

∅ 5,0 mm	29-02505	∅ 10,5 mm	29-02509
∅ 5,5 mm	29-02506	∅ 11,0 mm	29-02511
∅ 10,0 mm	29-02510	∅ 12,5 mm	29-02513



Sicherheitstrokar Dreikant

Reusable safety trocar (3-edge grinding)

∅ 5,0 mm	29-01025	∅ 11,0 mm	29-01031
∅ 5,5 mm	29-01026	∅ 12,5 mm	29-01032
∅ 10,0 mm	29-01030		



**Trokarhülsen mit Trompetenventil**

Trocar sleeves with trumpet valve

ø 15 mm 29-00515  
ø 20 mm 29-00520



**Trokare mit Dreikant-Spitze**

Trocars with three-edged tip

ø 15 mm 29-01515  
ø 20 mm 29-01520



**Trokare mit Kegel-Spitze**

Trocars with conical tip

ø 15 mm 29-02515  
ø 20 mm 29-02520

**Ersatzteile für Trokarhülsen**

Spare Parts for Trocar sleeves

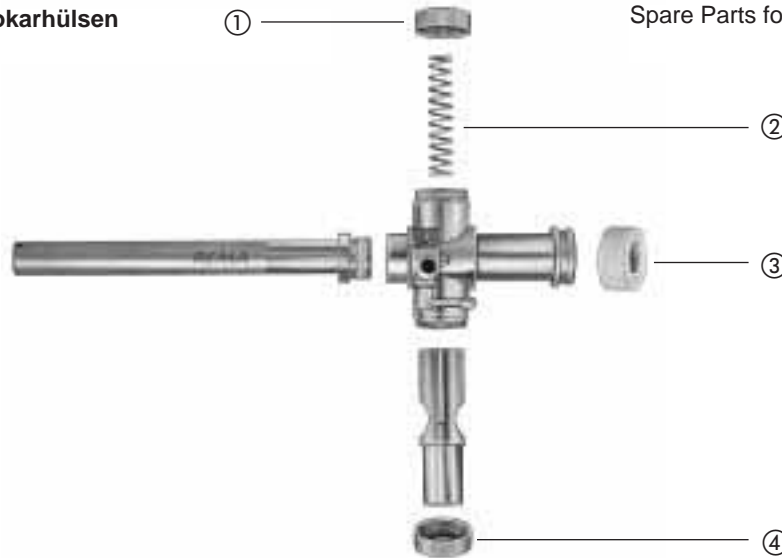

ø Trokargrößen Trocar sizes	① Ventilkappe, geschlossen Valve cap, closed	② Feder Spring	③ Dichtungskappe, 10 Stück Sealing cap, 10 pieces	④ Ventilkappe, offen Valve cap, open
5, 0 mm	29-00635	29-00642	29-00650	29-00661
5, 5 mm	29-00635	29-00642	29-00651	29-00661
10, 0 mm	29-00636	29-00643	29-00653	29-00662
10, 5 mm	29-00636	29-00643	29-00654	29-00662
11, 0 mm	29-00636	29-00644	29-00655	29-00662
12, 5 mm	29-00637	29-00645	29-00656	29-00663
15, 0 mm	29-00638	29-00647	29-00657	29-00664
20, 0 mm	29-00640	29-00648	29-00659	29-00666



Trocarhülsen mit Hahn und Klappventil

Trocar sleeves with stopcock and folding valve

∅ 5 mm	29-00535	∅ 11,0 mm	29-00541
∅ 5,5 mm	29-00536	∅ 12,5 mm	29-00542
∅ 10 mm	29-00540		



Automatiktrocarhülse mit manueller Klappenöffnung

Automatic trocar sleeve with manual Trap Door

∅ 5 mm	29-00735	∅ 11,0 mm	29-00741
∅ 5,5 mm	29-00736	∅ 12,5 mm	29-00742
∅ 10 mm	29-00740		

### Ersatzteile für Trocarhülsen

### Spare parts for trocar sleeves



∅ Trocargrößen Trocar sizes	① Dichtungsring, 10 Stück Sealing ring, 10 pieces	② Dichtungsring 10 Stück Sealing ring, 10 pieces	③ Überwurfmutter Screw cap	④ Dichtungskappe, 10 Stück Sealing cap, 10 pieces
∅ 5,0 mm	29-00670	29-00675	29-00678	29-00684
∅ 5,5 mm	29-00670	29-00675	29-00678	29-00685
∅ 10,0 mm	29-00671	29-00676	29-00679	29-00686
∅ 10,5 mm	29-00671	29-00676	29-00679	29-00687
∅ 11,0 mm	29-00671	29-00676	29-00679	29-00688
∅ 12,5 mm	29-00671	29-00676	29-00679	29-00689



Trocar-Stop

Trocar-Stop

∅ 5,0 mm	29-00090	∅ 10,5 mm	29-00093
∅ 5,5 mm	29-00091	∅ 11,0 mm	29-00094
∅ 10,0 mm	29-00092	∅ 12,5 mm	29-00095



Reduzierhülsen

Reducer sleeves

∅ 10,0 mm → ∅ 5,0 mm	29-00103	∅ 15,0 mm → ∅ 10,0 mm	29-00113
∅ 11,0 mm → ∅ 5,0 mm	29-00104	∅ 15,0 mm → ∅ 11,0 mm	29-00114
∅ 12,5 mm → ∅ 5,0 mm	29-00106	∅ 20,0 mm → ∅ 5,0 mm	29-00116
∅ 12,5 mm → ∅ 10,0 mm	29-00108	∅ 20,0 mm → ∅ 10,0 mm	29-00118
∅ 15,0 mm → ∅ 5,0 mm	29-00110	∅ 20,0 mm → ∅ 11,0 mm	29-00120



Dilatations-Sätze, bestehend aus  
 Dilatationsstab und Dilatationshülse

Dilation sets, consisting of dilation rod and  
 dilation sleeve

∅ 5,0 mm → ∅ 10,0 mm	29-00132	∅ 10,0 mm → ∅ 20,0 mm	29-00146
∅ 5,0 mm → ∅ 15,0 mm	29-00140	∅ 11,0 mm → ∅ 15,0 mm	29-00148
∅ 5,0 mm → ∅ 20,0 mm	29-00142	∅ 11,0 mm → ∅ 20,0 mm	29-00150
∅ 10,0 mm → ∅ 15,0 mm	29-00144		



Insufflations-Kanüle nach Veress

Insufflation needle acc. to Veress

2.00 x 100 mm	29-00160	2.00 x 200 mm	29-00170
2.00 x 120 mm	29-00162		
2.00 x 140 mm	29-00164		
2.00 x 150 mm	29-00165		



Taststab graduert

Palpation probe graduated

330 mm	∅ 5 mm	29-03510
450 mm	∅ 5 mm	29-03511

Sämtliche Optiken sind mit einem drei-teiligen Lichtkabel-Anschluß ausgestattet:

All telescopes are equipped with a 3-way variable cable connector to connect the following systems:

ACM, BRITISH, WOLF, HSW, STORZ, OLYMPUS



Optiken für die Laparoskopie, autoklavierbar bei 2,3 bar (134°C)

Optics for laparoscopy autoclavable at 2,3 bar (134°C)

ø 5 mm	Geradausblick 0°	31-00010
ø 5 mm	Vorausblick 30°	31-00020
ø 10 mm	Geradausblick 0°	31-00030
ø 10 mm	Vorausblick 30°	31-00040
ø 10 mm	Vorausblick 45°	31-00050

ø 5 mm	direkt vision 0°	31-00010
ø 5 mm	forobilique 30°	31-00020
ø 10 mm	direkt version 0°	31-00030
ø 10 mm	forobilique 30°	31-00040
ø 10 mm	forobilique 45°	31-00050



Sterilisierbarer Optikwärmer, schützt die Optik außerhalb des OP-Feldes vor Wärmeverlust

Sterilizable optic heater protects the optics outside of the OP-field of loss of heat

für 5 mm Optiken	31-00100
für 10 mm Optiken	31-00110

for 5 mm Optics	31-00100
for 10 mm Optics	31-00110



**Fiber-Lichtleitkabel, autoklavierbar bei 2 bar (134°C)**

**Fibre Light cables, autoclavable at 2 bar (134°C)**

Projektor-Adapter / Endoskop-Adapter		∅	180 Länge/length	230 Länge/length	300 Länge/length
Rema/Storz	Rema/Storz	4,8	31-00200	31-00201	31-00202
	Winter/Ibe	6,0	31-00205	31-00206	31-00207
Winter/Ibe	Rema/Storz	4,8	31-00210	31-00211	31-00212
	Winter/Ibe	6,0	31-00215	31-00216	31-00217
Wolf/HSW	Wolf/HSW	4,8	31-00220	31-00221	31-00222
		6,0	31-00225	31-00226	31-00227
ACM/British	ACM/British	4,8	31-00230	31-00231	31-00232
		6,0	31-00235	31-00236	31-00237

**Winkel Anschluß für Projektor Seite 31-00300**

**angle connection for projector side 31-00300**

Typ A



Typ B



**HF Verbindungskabel Typ A Länge 3,50 m**  
**HF Verbindungskabel Typ B Länge 3,50 m**

**HF Connection cable Type A Length 3,50 m**  
**HF Connection cable Type B Length 3,50 m**

**Typ A 28-00000**  
**Typ B 28-00500**

**Type A 28-00000**  
**Type B 28-00500**

Hakenelektrode bis maximal nach vorne isoliert

Hook-tip electrodes insulated up to the front, to the maximum extent

Typ A

Type A



Typ B

Type B



geeignet für: REMA Handgriffe zur individuellen Längeneinstellung des Instrumentenarms Nr. 28-00100

suitable for: REMA handle for individual length adjustment of instrument arm. No. 28-00100



stumpf

	Typ A	Typ B
Länge 330 mm	28-00001	28-00501
Länge 450 mm	28-00101	28-00601

blunt

	Typ A	Typ B
length 330 mm	28-00001	28-00501
length 450 mm	28-00101	28-00601



Rautenförmige Schnittfläche

	Typ A	Typ B
Länge 330 mm	28-00002	28-00502
Länge 450 mm	28-00102	28-00602

diamond shaped cutting surface

	Typ A	Typ B
length 330 mm	28-00002	28-00502
length 450 mm	28-00102	28-00602



stumpf

	Typ A	Typ B
Länge 330 mm	28-00003	28-00503
Länge 450 mm	28-00103	28-00603

blunt

	Typ A	Typ B
length 330 mm	28-00003	28-00503
length 450 mm	28-00103	28-00603



Rautenförmige Schnittfläche

	Typ A	Typ B
Länge 330 mm	28-00004	28-00504
Länge 450 mm	28-00104	28-00604

diamond shaped cutting surface

	Typ A	Typ B
length 330 mm	28-00004	28-00504
length 450 mm	28-00104	28-00604



Rautenförmige Schnittfläche

	Typ A	Typ B
Länge 330 mm	28-00005	28-00505
Länge 450 mm	28-00105	28-00605

diamond shaped cutting surface

	Typ A	Typ B
length 330 mm	28-00005	28-00505
length 450 mm	28-00105	28-00605

pat. pend.

Hakenelektrode bis maximal nach vorne und auch auf der Rückseite bis zur Spitze isoliert

Hook-tip electrodes insulated up to the front, to the maximum extent, as well as on the back up to the tip

Typ A

Type A



Typ B

Type B



geeignet für: REMA Handgriffe zur individuellen Längeneinstellung des Instrumentenarms Nr. 28-00100

suitable for: REMA handle for individual length adjustment of instrument arm. No. 28-00100



gebogen stumpf

blunt curved

	Typ A	Typ B
Länge 330 mm	28-00011	28-00511
Länge 450 mm	28-00111	28-00611

	Typ A	Typ B
length 330 mm	28-00011	28-00511
length 450 mm	28-00111	28-00611



Rautenförmige Schnittfläche

diamond shaped cutting surface

	Typ A	Typ B
Länge 330 mm	28-00012	28-00512
Länge 450 mm	28-00112	28-00612

	Typ A	Typ B
length 330 mm	28-00012	28-00512
length 450 mm	28-00112	28-00612



stumpf

blunt

	Typ A	Typ B
Länge 330 mm	28-00013	28-00513
Länge 450 mm	28-00113	28-00613

	Typ A	Typ B
length 330 mm	28-00013	28-00513
length 450 mm	28-00113	28-00613



Rautenförmige Schnittfläche

diamond shaped cutting surface

	Typ A	Typ B
Länge 330 mm	28-00014	28-00514
Länge 450 mm	28-00114	28-00614

	Typ A	Typ B
length 330 mm	28-00014	28-00514
length 450 mm	28-00114	28-00614



Rautenförmige Schnittfläche

diamond shaped cutting surface

	Typ A	Typ B
Länge 330 mm	28-00015	28-00515
Länge 450 mm	28-00115	28-00615

	Typ A	Typ B
length 330 mm	28-00015	28-00515
length 450 mm	28-00115	28-00615

pat.pend.



Typ A

Type A



Typ B

Type B



### Knopf-Elektrode

	Typ A	Typ B
Länge 300 mm	28-00020	28-00520
Länge 450 mm	28-00120	28-00620

### Button tip electrode

	Typ A	Typ B
length 300 mm	28-00020	28-00520
length 450 mm	28-00120	28-00620



### Konus-Elektrode

	Typ A	Typ B
Länge 300 mm	28-00021	28-00521
Länge 450 mm	28-00121	28-00621

### Cone tip electrode

	Typ A	Typ B
length 300 mm	28-00021	28-00521
length 450 mm	28-00121	28-00621



### Messer-Elektrode

	Typ A	Typ B
Länge 300 mm	28-00022	28-00522
Länge 450 mm	28-00122	28-00622

### Knife tip electrode

	Typ A	Typ B
length 300 mm	28-00022	28-00522
length 450 mm	28-00122	28-00622



### Schlingenelektrode

	Typ A	Typ B
Länge 300 mm	28-00023	28-00523
Länge 450 mm	28-00123	28-00623

### Loop tip electrode

	Typ A	Typ B
length 300 mm	28-00023	28-00523
length 450 mm	28-00123	28-00623



**Koagulations-Saugrohr, isoliert mit  
Trompetenventil** 27-00001

coagulation and suction-cannula, insulated,  
with trumpet valve 27-00001



**Dissektions-Spatel, isoliert, mit Absaugung  
und Trompetenventil** 27-00002

Dissecting Spatula, insulated, with trumpet  
valve and suction 27-00002



**Dissektionshaken, isoliert, mit Absaugung  
und Trompetenventil** 27-00003

Dissecting Hook, insulated, with trumpet  
valve and suction 27-00003



**Dissektionshaken, rechtwinklig, isoliert, mit  
Absaugung und Trompetenventil** 27-00004

Dissecting Hook, right-angled, insulated, with  
trumpet valve and suction 27-00004



**Koagulations-Saugrohr, isoliert** 27-00011

coagulation and suction-cannula, insulated  
27-00011



**Dissektions-Spatel, isoliert, mit Absaugung** 27-00012

Dissecting Spatula, insulated, with suction  
27-00012



**Dissektionshaken, isoliert, mit Absaugung** 27-00013

Dissecting Hook, insulated, with suction  
27-00013



**Dissektionshaken, rechtwinklig, isoliert, mit  
Absaugung** 27-00014

Dissecting Hook, right-angled, insulated, with  
suction 27-00014



**27-00600 komplett**

**Saug-Spülrohr-Set ø 5 mm  
bestehend aus:  
7 Saug- und Spülrohren Fig. 1 bis 7  
1 Schiebeventil**

**27-00601 Schiebeventil einzeln**

**27-00600 complete**

**Suction-Irrigation tube set ø 5 mm  
consisting of:  
7 Suction-Irrigation tubes Fig. 1 to 7  
1 Sliding valve**

**27-00601 Sliding valve only**



**27-00602 komplett**

**Saug-Spülrohr-Set ø 5 mm  
bestehend aus:  
7 Saug- und Spülrohren Fig. 1 bis 7  
1 Trompetenventil**

**27-00603 Trompetenventil einzeln**

**27-00602 complete**

**Suction-Irrigation tube set ø 5 mm  
consisting of:  
7 Suction-Irrigation tubes Fig. 1 to 7  
1 Trumpet valve**

**27-00603 Trumpet valve only**



**Saug-Spülrohr  
27-00610 Fig. 1**

**Suction-Irrigation tube  
27-00610 Fig. 1**



**Saug-Spülrohr  
27-00611 Fig. 2**

**Suction-Irrigation tube  
27-00611 Fig. 2**



**Saug-Spülrohr  
27-00612 Fig. 3  
27-00613 Fig. 4 wie oben, jedoch 500 mm**

**Suction-Irrigation tube  
27-00612 Fig. 3  
27-00613 Fig. 4 see above, but 500 mm**



**Saug-Spülrohr  
27-00614 Fig. 5**

**Suction-Irrigation tube  
27-00614 Fig. 5**



**Saug-Spülrohr  
27-00615 Fig. 6**

**Suction-Irrigation tube  
27-00615 Fig. 6**



**Saug-Spülrohr  
27-00616 Fig. 7**

**Suction-Irrigation tube  
27-00616 Fig. 7**



**27-00620 komplett**

**Saug-Spülrohr-Set  
bestehend aus:  
27-00621 Saug-Spülrohr ø 5 mm  
27-00622 Saug-Spülrohr ø 10 mm  
27-00623 Trompetenventil**

**27-00620 complete**

**Suction-Irrigation tube set  
consisting of:  
27-00621 Suction-Irrigation tube ø 5 mm  
27-00622 Suction-Irrigation tube ø 10 mm  
27-00623 Trumpet valve**



**27-00008**  
**Saug-Spülkanüle mit Laserführung**

**27-00008**  
 Suction and Irrigation tube, with central tube laser fiber



**27-00005**  
**Saug-Spülkanüle mit Laserführung**

**27-00005**  
 Suction and Irrigation tube, with central tube laser fiber



**27-00006**  
**Saugrohr, mit Hahn und Luer Lock Anschluß**

**27-00006**  
 Suction tube with stop cock, Luer Lock



**27-00007**  
**Saug- und Spülkanüle, mit zwei Trompetenventilen**

**27-00007**  
 Suction and Irrigation tube, with two trumpet valves



**27-00015 ø 6 mm**  
**27-00016 ø 8 mm**  
**Schlauchverbindung mit Luer Lock Anschluß**  
**(weiblich)**

**27-00015 ø 6 mm**  
**27-00016 ø 8 mm**  
 connector, Luer Lock  
 (female)



**27-00017 ø 6 mm**  
**27-00018 ø 8 mm**  
**Schlauchverbindung mit Luer Lock Anschluß**  
**(männlich)**

**27-00017 ø 6 mm**  
**27-00018 ø 8 mm**  
 connector, Luer Lock  
 (male)



**27-00039**  
**Cholangiographie-Fixierzange**

27-00039  
Cholangiographie Fixation forceps



**27-00041**  
**Injektionsnadel, Luer Lock**

27-00041  
Injection and puncture needle, Luer Lock



**27-00042**  
**Zwei-Wege-Anschluß für Kontrastmittel**

27-00042  
Two-way stopcock for contrast medium



**27-00043**  
**Führungsrohr für Cholangiokatheter**

27-00043  
Guide tube for Cholangiocatheter



**27-00044**  
**Führungshäkchen für Cholangiokatheter**

27-00044  
Guide hook for Cholangiocatheter

# NEW NEW NEW NEW

## REMA'S NEUE LAPAROSKOPIE INSTRUMENTEN LINIE - „easy change“

Folgende Eigenschaften zeichnen die neueste REMA Laparoskopie Serie "easy change line" aus:

- Ergonomisches Leichtdesign, hervorragende Reinigungseigenschaften wie z.B. schnell, effektiv und einfach. Zusätzlich bietet jedes Instrument die Möglichkeit einer extra schnellen Reinigung über "Luer Lock".
- Einfachste Bedienung da Griff vom Instrument mit einem Fingerdruck zu entfernen ist, entspricht einem Schnellverschluß da keine Schrauben mehr benutzt werden.
- Für Griffe mit Sperre haben wir ein neues komfortables Sperren Design mit leichter Handhabung entwickelt. Die Fingerstellung des Anwenders ist die selbe wie beim Benutzen eines Griffes ohne Sperre. Die Behinderung durch die herkömmliche Sperre am Griff entfällt.

"Easy change line" ist in 5mm und 10mm erhältlich, NEU !! für die 5mm Einsätze sowie für die 10mm wird der gleiche Griff benutzt. Alle sind 360° rotierbar und autoklavierbar. Alle Instrumente sind schnell und einfach in 3 Einzelteile zerlegbar: Griff, Außenrohr und Arbeitselement.

## NEW REMA LAPAROSCOPY INSTRUMENT LINE - „easy change“







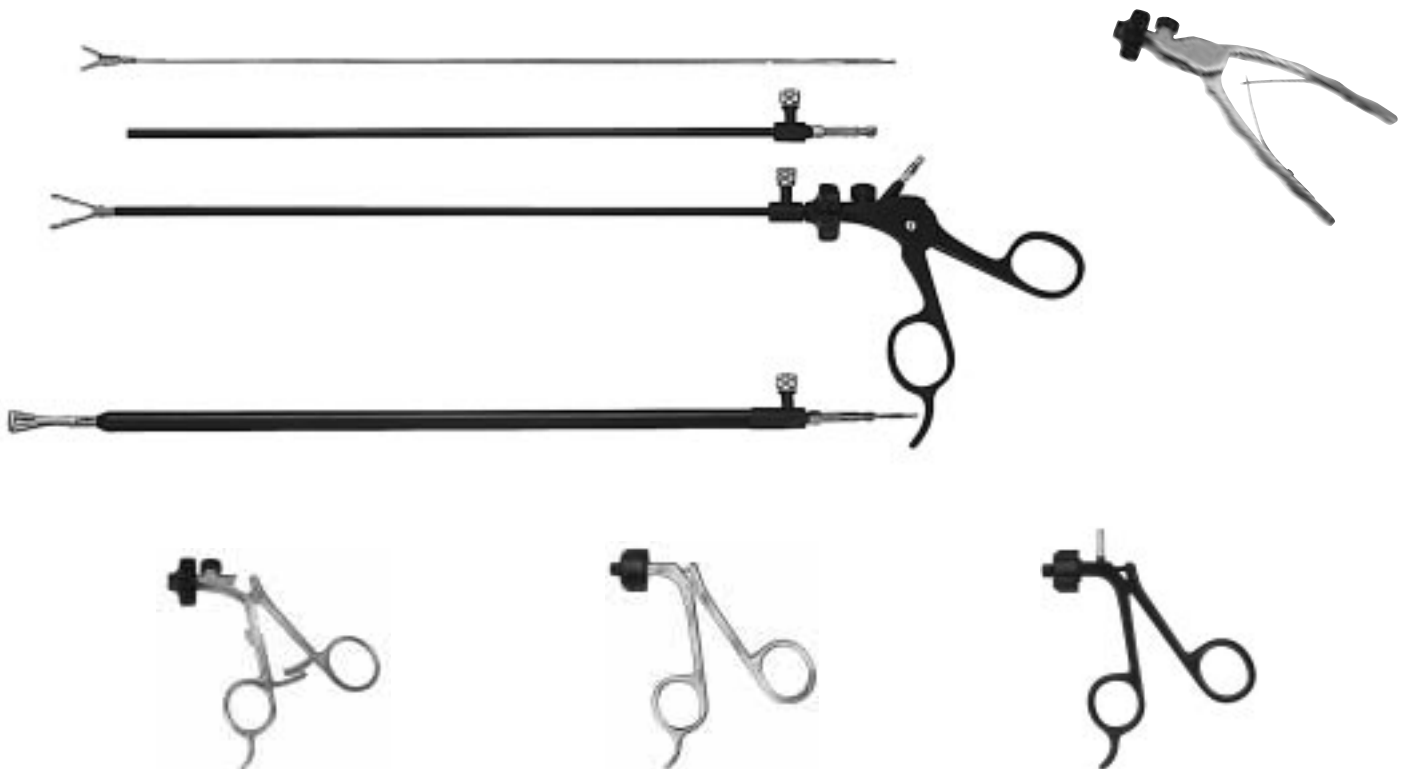







The following benefits offers the newest REMA Laparoscopy instrument line "easy change":

- Ergonomic light design, excellent cleaning quality e.g. fast, effective and simple. Every instrument features additionally extra fast cleaning possibility via "Luer Lock".
- Very easy and simple handling as handle can be removed by pressing with one finger, this corresponds to a quick lock as no screws are used any longer.
- For handles with ratchet we developed a new comfortable ratchet design with easy handling. The users finger posture is the same like holding a handle without ratchet. The handicap through the traditional ratchet on the handle is cancelled.

"Easy change line" is in 5mm and in 10mm available. **NEW !!** for 5mm inserts as well as for the 10mm you use the same handle. All instruments are 360° rotatable and autoclavable. Can be taken apart fast and easily into 3 parts: handle, outer tube and working insert.

















NEW NEW NEW NEW NEW NEW NEW NEW

	Länge Working length	Griff allein Handle 32-000-001	Griff allein Handle 32-000-003	Griff allein Handle 32-000-005	Griff allein Handle 32-000-007	Griff allein Handle 32-000-047
	330 mm					
	430 mm					
	<b>Einsatz Nr.</b> Insert no.	<b>Komplettes Instrument 5 mm</b> Complete Instrument 5 mm				
	<b>Hakenschere, gerade</b> / Hook scissors, straight					
	32-051-000	32-051-101				
	33-051-000	33-051-101				
	<b>Peritonealschere, gerade</b> / Peritoneal scissors, straight					
	32-082-000	32-082-101				
	33-082-000	33-082-101				
	<b>Mikro-Dissektionsschere, gerade</b> / Micro dissecting scissors, straight					
	32-048-000	32-048-101		32-048-105		
	<b>Mikro-Dissektionsschere, links gebogen</b> / Micro dissecting scissors, curved left					
	32-049-000	32-049-101		32-049-105		
	<b>METZENBAUM, Dissektionsschere, kurz, gebogen</b> / METZENBAUM, Dissecting scissors, short, curved					
	32-047-000	32-047-101				
	<b>METZENBAUM, Dissektionsschere, gerade</b> / METZENBAUM, Dissecting scissors, straight					
	32-054-000	32-054-101				
	33-054-000	33-054-101				
	<b>METZENBAUM, Dissektionsschere, gebogen</b> / METZENBAUM, Dissecting scissors, curved					
	32-056-000	32-056-101				
	33-056-000	33-056-101				
	<b>Biopsiezange</b> / Biopsy forceps					
	32-063-000	32-063-101				
	33-063-000	33-063-101				
	<b>Biopsiezange mit Dorn</b> / Biopsy forceps with thorn					
	32-064-000	32-064-101				
	33-064-000	33-064-101				

**Außenrohr / Outer Tube**    330 mm 32-000-100 5mm  
430 mm 33-000-100 5mm



- Alle weiteren Griffkombinationen sind selbstverständlich auch möglich.
- All further handle-combinations are also possible of course.
- Der Vorteil der neuen "easy change" - Instrumente besteht in der Isolierung, welche bis vor zur Maulspitze reicht.
- The advantage of the new "easy change" - instruments is the isolation, which reaches until the top of the instrument.















	Länge Working length	Griff allein Handle 32-000-001	Griff allein Handle 32-000-003	Griff allein Handle 32-000-005	Griff allein Handle 32-000-007	Griff allein Handle 32-000-047
	330 mm					
	430 mm					
	Einsatz Nr. Insert no.	Komplettes Instrument 5 mm Complete Instrument 5 mm				
	<b>BLAKESLY, Biopsiezange / BLAKESLY, Biopsy forceps</b>					
	32-081-000	32-081-101				
	33-081-000	33-081-101				
	<b>Biopsiestanze / Biopsy punch</b>					
	32-060-000	32-060-101				
	33-060-000	33-060-101				
	<b>Biopsiestanze / Biopsy punch</b>					
	32-062-000	32-062-101				
	33-062-000	33-062-101				
	<b>Fasszange / Grasping forceps</b>					
	32-065-000	32-065-101	32-065-103			
	33-065-000	33-065-101	33-065-103			
	<b>Fasszange Fenestrated / Grasping forceps Fenestrated</b>					
	32-079-000		32-079-103			
	33-079-000		33-079-103			
	<b>Fasszange, feines Modell / Grasping forceps, delicate pattern</b>					
	32-066-000		32-066-103			
	33-066-000		33-066-103			
	<b>Fasszange, kräftiges Maul / Grasping forceps, heavy pattern</b>					
	32-078-000		32-078-103			
	33-078-000		33-078-103			
	<b>Fasszange / Grasping forceps</b>					
	32-068-000		32-068-103			
	33-068-000		33-068-103			
	<b>Fasszange, spitz / Grasping forceps, pointed</b>					
	32-069-000		32-069-103			
	33-069-000		33-069-103			

**Außenrohr / Outer Tube** 330 mm 32-000-100 5mm  
 430 mm 33-000-100 5mm



- Alle weiteren Griffkombinationen sind selbstverständlich auch möglich.
- All further handle-combinations are also possible of course.
- Der Vorteil der neuen "easy change" - Instrumente besteht in der Isolierung, welche bis vor zur Maulspitze reicht.
- The advantage of the new "easy change" - instruments is the isolation, which reaches until the top of the instrument.













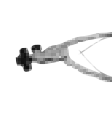

NEW NEW NEW NEW NEW NEW NEW NEW

	Länge Working length	Griff allein Handle 32-000-001	Griff allein Handle 32-000-003	Griff allein Handle 32-000-005	Griff allein Handle 32-000-007	Griff allein Handle 32-000-047
	330 mm					
	430 mm					
	Einsatz Nr. Insert no.	Komplettes Instrument 5 mm Complete Instrument 5 mm				
	<b>Fasszange / Grasping forceps</b>					
	32-075-000		32-075-103			
	33-075-000		33-075-103			
	<b>Dissektionszange, atraumatisch / Dissecting forceps, atraumatic serration</b>					
	32-070-000	32-070-101	32-070-103			
	33-070-000	33-070-101	33-070-103			
	<b>MARYLAND, Dissektionszange, gebogen / MARYLAND, Dissecting forceps, curved</b>					
	32-072-000	32-072-101				
	33-072-000	33-072-101				
	<b>Dissektionszange, gebogen 45° / Dissecting forceps, curved 45°</b>					
	32-246-000	32-246-101		32-246-105		
	33-246-000	33-246-101		33-246-105		
	<b>Dissektionszange, gebogen 90° / Dissecting forceps, curved 90°</b>					
	32-247-000	32-247-101		32-247-105		
	<b>Fasszange, atraumatisch, De Bakey / Grasping forceps, atraumatic, De Bakey</b>					
	32-242-000		32-242-103		32-242-107	
	33-242-000		33-242-103		33-242-107	
	<b>Fasszange / Grasping forceps</b>					
	32-077-000		32-077-103			
	33-077-000		33-077-103			
	<b>Fasszange 2x3 Zähne / Grasping forceps 2x3 teeth</b>					
	32-076-000		32-076-103			
	33-076-000		33-076-103			
	<b>Krallengreifer 2x3 Zähne / Claw forceps 2x3 teeth</b>					
	32-083-000		32-083-103		32-083-107	

**Außenrohr / Outer Tube** 330 mm 32-000-100 5mm  
430 mm 33-000-100 5mm



- Alle weiteren Griffkombinationen sind selbstverständlich auch möglich.  
All further handle-combinations are also possible of course.
- Der Vorteil der neuen "easy change" - Instrumente besteht in der Isolierung, welche bis vor zur Maulspitze reicht.  
The advantage of the new "easy change" - instruments is the isolation, which reaches until the top of the instrument.

	Länge Working length	Griff allein Handle 32-000-001	Griff allein Handle 32-000-003	Griff allein Handle 32-000-005	Griff allein Handle 32-000-007	Griff allein Handle 32-000-047
	330 mm					
	430 mm					
	Einsatz Nr. Insert no.	Komplettes Instrument 5 mm Complete Instrument 5 mm				
	<b>Fasszange HI mit Hartmetall-Einlage / Grasping forceps HI with tungsten carbide</b>					
	32-286-000		32-286-103		32-286-107	
	33-286-000		33-286-103		33-286-107	
	<b>ALLIS, Fasszange / ALLIS, Grasping forceps</b>					
	32-105-000		32-105-103		32-105-107	
	<b>ALLIS, Fasszange, atraumatisch, De Bakey / ALLIS, Grasping forceps, atraumatic, De Bakey</b>					
	32-111-000		32-111-103		32-111-107	
	<b>Endo-Klemme, einfach DeBakey mit Schließschutz / Endo-Forceps with single DeBakey, closing protection</b>					
	32-198-000		32-198-103		32-198-107	
	<b>KOCHER, Fasszange, atraumatisch, De Bakey / KOCHER, Grasping forceps, atraumatic, De Bakey</b>					
	32-171-000		32-171-103		32-171-107	
	<b>Endo-Lungentastzange / Endo-Lung Palpation forceps</b>					
	32-233-000	32-233-101		32-233-105		
	<b>Dissektionszange 90° gebogen, für Verwendung mit 12,5 mm Trokarhülse / Dissecting forceps 90° curved, using with 12,5 mm trocar sleeve</b>					
	32-067-000	32-067-101		32-067-105		
	<b>Nadelhalter mit Hartmetall-Einlagen 8 mm / Needle holder with tungsten carbide inserts 8mm</b>					
	32-201-000				32-201-107	32-201-147
	<b>Nahtfasszange, U-förmiges Maul / Suture fixation forceps, U-shaped jaws</b>					
	32-248-000				32-248-107	32-248-147













**Außenrohr / Outer Tube**  
330 mm 32-000-100 5mm  
430 mm 33-000-100 5mm



- Alle weiteren Griffkombinationen sind selbstverständlich auch möglich.
- All further handle-combinations are also possible of course.
- Der Vorteil der neuen "easy change" - Instrumente besteht in der Isolierung, welche bis vor zur Maulspitze reicht.
- The advantage of the new "easy change" - instruments is the isolation, which reaches until the top of the instrument.

NEW  
NEW  
NEW  
NEW  
NEW  
NEW  
NEW  
NEW







NEW NEW NEW NEW NEW

	Länge Working length	Griff allein Handle 32-000-001	Griff allein Handle 32-000-003	Griff allein Handle 32-000-005	Griff allein Handle 32-000-007	
	330 mm					
	Einsatz Nr. Insert no.	Komplettes Instrument 10 mm Complete Instrument 10 mm				
	<b>Große Operationsschere / Operating scissors, large</b>	32-084-000	32-084-201		32-084-205	
	<b>Große Löffelzange / Spoon forceps, large</b>	32-180-000	32-180-201	32-180-203		32-180-207
	<b>Krallengreifer 2x3 Zähne / Claw forceps 2x3 teeth</b>	32-179-000		32-179-203		32-179-207
	<b>Fasszange, kräftiges Modell / Grasping forceps, heavy pattern</b>	32-225-000		32-225-203		32-225-207
	<b>MARYLAND, Dissektionszange, gebogen / MARYLAND, Dissecting forceps, curved</b>	32-074-000	32-074-201	32-074-203		
	<b>ALLIS, Fasszange / ALLIS, Grasping forceps</b>	32-101-000		32-101-203		32-101-207
	<b>ALLIS, Fasszange, atraumatisch, DeBakey / ALLIS, Grasping forceps, atraumatic, DeBakey</b>	32-108-000		32-108-203		32-108-207
	<b>BABCOCK, Fasszange / BABCOCK, Grasping forceps</b>	32-120-000		32-120-203		32-120-207
	<b>BABCOCK, Fasszange, atraumatisch, DeBakey / BABCOCK, Grasping forceps, atraumatic, DeBakey</b>	32-123-000		32-123-203		32-123-207

Außenrohr / Outer Tube 330 mm 32-000-200 10 mm



- , Alle weiteren Griffkombinationen sind selbstverständlich auch möglich.
- , All further handle-combinations are also possible of course.
- , Der Vorteil der neuen "easy change" - Instrumente besteht in der Isolierung, welche bis vor zur Maulspitze reicht.
- , The advantage of the new "easy change" - instruments is the isolation, which reaches until the top of the instrument.

	<b>Länge</b> Working length	<b>Griff allein</b> Handle <b>32-000-001</b>	<b>Griff allein</b> Handle <b>32-000-003</b>	<b>Griff allein</b> Handle <b>32-000-005</b>	<b>Griff allein</b> Handle <b>32-000-007</b>		
	<b>330 mm</b>						
	<b>Einsatz Nr.</b> Insert no.	<b>Komplettes Instrument 10 mm</b> Complete Instrument 10 mm					
	<b>DUVAL, Fasszange / DUVAL, Grasping forceps</b>						
	<b>32-176-000</b>		<b>32-176-203</b>		<b>32-176-207</b>		
	<b>COLLIN, Fasszange, atraumatisch/ COLLIN, Grasping forceps, atraumatic</b>						
	<b>32-181-000</b>		<b>32-181-203</b>		<b>32-181-207</b>		
	<b>Dissektions-Fasszange, atraumatisch, DeBakey / Dissecting-Grasping forceps, atraumatic, DeBakey</b>						
	<b>32-080-000</b>	<b>32-080-201</b>	<b>32-080-203</b>				

NEW  
NEW  
NEW  
NEW  
NEW  
NEW

**Außenrohr / Outer Tube 330 mm 32-000-200 10 mm**



- , Alle weiteren Griffkombinationen sind selbstverständlich auch möglich.
- , All further handle-combinations are also possible of course.
- , Der Vorteil der neuen "easy change" - Instrumente besteht in der Isolierung, welche bis vor zur Maulspitze reicht.
- , The advantage of the new "easy change" - instruments is the isolation, wich reaches until the top of the instrument.



Mit den zerlegbaren Instrumenten stellt REMA die neueste Generation laparoskopischer Instrumente vor. Instrumente die ohne größeren Aufwand zerlegt und mit einer bisher nicht möglichen Gründlichkeit gereinigt werden können. Zusätzlich lassen sich durch das einzigartige Konstruktionsprinzip die auswechselbaren Grundelemente eines jeden Instruments mit verschiedenen Handgriffen kombinieren.

Im Falle von Abnutzung des Instrumenteneinsatzes kann er durch einen fabrikneuen Einsatz ausgetauscht werden. Dies führt zu einer deutlichen Kostensenkung, da nur der Instrumenteneinsatz und nicht das komplette Instrument ersetzt werden muß.

Die zerlegbaren REMA-Instrumente bieten somit bestmöglichen Schutz vor Infektionen. Sie sind anwenderfreundlich, unter anderem durch die einfache Zerlegbarkeit und die Kombination der Instrumenteneinsätze mit verschiedenen Handgriffen. Sie sind kostensenkend, da die Grundelemente wie Handgriff und Instrumenteneinsatz separat bestellt werden können. Diese Instrumente bieten eine deutlich verbesserte Kosten-Nutzen-Relation.

With the detachable instruments REMA introduces the latest generation of laparoscopic instruments, which can be easily disassembled for a thorough, so far not possible, cleaning. Through the unique constructional conception, it is also possible, that the interchangeable basic elements of each instrument can be combined with various handles.

In case of erosion of the instruments insert, it can be replaced by a new one. This leads to a clear lowering of costs, as only the instruments insert has to be exchanged and not the complete instrument.

The detachable REMA instruments offer therefore best possible protection against infection, and they are userfriendly through a easy disassembly and the combination of the instrument inserts with various handles. As the basic elements like handle and instrument insert can be ordered separately they are cost lowering. These instruments offer a clearly improved cost-use relation.

**INSTRUMENT IN MONTIERTEM ZUSTAND**

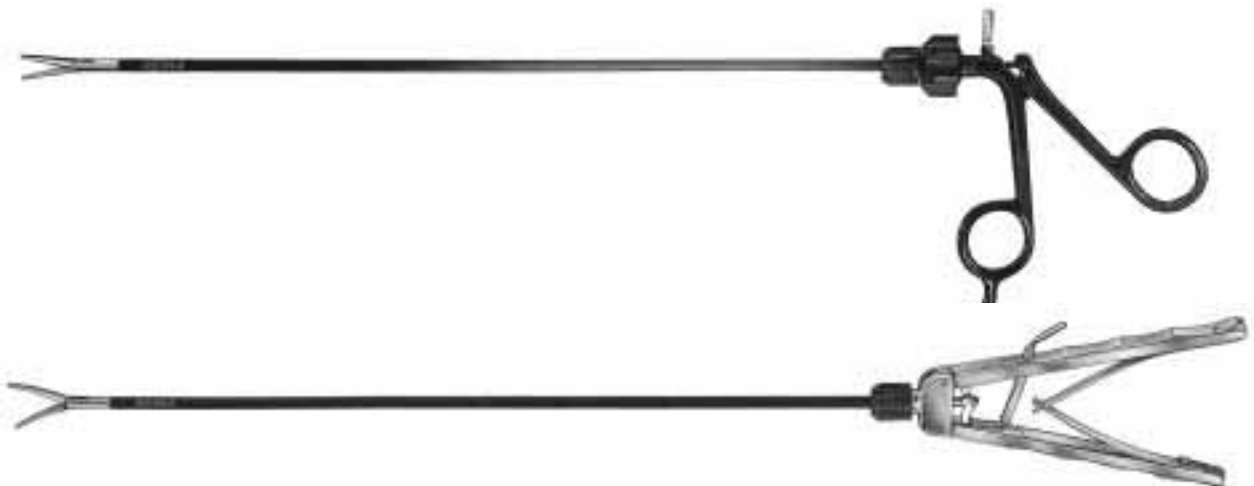

**ASSEMBLED INSTRUMENT**



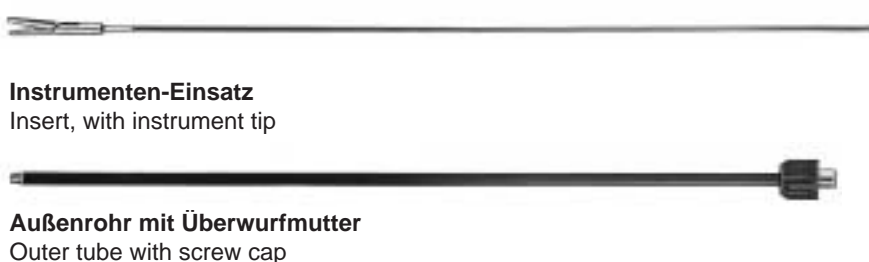











**INSTRUMENT IN DEMONTIERTEM ZUSTAND**



**DISASSEMBLED INSTRUMENT**

















## Scheren, Ø 5 mm Scissors, Ø 5 mm

	Länge Working length	Griff allein Handle 28-000-001	Griff allein Handle 28-000-003	Griff allein Handle 28-000-005	Griff allein Handle 28-000-007	Griff allein Handle 28-000-047
	330 mm					
	430 mm					
	Einsatz Nr. Insert no.	Komplettes Instrument 5 mm Complete Instrument 5 mm				
	<b>Hakenschere, gerade / Hook scissors, straight</b>					
	28-051-000	28-051-101				
	26-051-000	26-051-101				
	<b>Hakenschere, links gebogen / Hook scissors, curved left</b>					
	28-053-000	28-053-101				
	<b>Peritonealschere, gerade / Peritoneal scissors, straight</b>					
	28-082-000	28-082-101				
	26-082-000	26-082-101				
	<b>Mikro-Dissektionsschere, gerade / Micro dissecting scissors, straight</b>					
	28-048-000	28-048-101		28-048-105		
	<b>Mikro-Dissektionsschere, links gebogen / Micro dissecting scissors, curved left</b>					
	28-049-000	28-049-101		28-049-105		
	<b>METZENBAUM, Dissektionsschere, gerade / METZENBAUM, Dissecting scissors, straight</b>					
	28-046-000	28-046-101				
	<b>METZENBAUM, Dissektionsschere, gebogen / METZENBAUM, Dissecting scissors, curved</b>					
	28-047-000	28-047-101				
	<b>METZENBAUM, Dissektionsschere, gerade / METZENBAUM, Dissecting scissors, straight</b>					
	28-054-000	28-054-101				
	26-054-000	26-054-101				
	<b>METZENBAUM, Dissektionsschere, gebogen / METZENBAUM, Dissecting scissors, curved</b>					
	28-056-000	28-056-101				
	26-056-000	26-056-101				











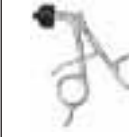
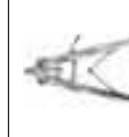

**Außenrohr / Outer Tube** 330 mm 28-000-100 5mm  
430 mm 26-000-100 5mm



	Länge Working length	Griff allein Handle 28-000-001	Griff allein Handle 28-000-003	Griff allein Handle 28-000-005	Griff allein Handle 28-000-007	Griff allein Handle 28-000-047
	330 mm					
	430 mm					
	Einsatz Nr. Insert no.	Komplettes Instrument 5 mm Complete Instrument 5 mm				
	<b>METZENBAUM, Dissektionsschere, gerade, gezahnt / METZENBAUM, Dissecting scissors, straight, with teeth</b>					
	28-057-000	28-057-101				
	26-057-000	26-057-101				
	<b>METZENBAUM, Dissektionsschere, gebogen, gezahnt / METZENBAUM, Dissecting scissors, curved, with teeth</b>					
	28-059-000	28-059-101				
	26-059-000	26-059-101				
	<b>Biopsiezange / Biopsy forceps</b>					
	28-063-000	28-063-101				
	26-063-000	26-063-101				
	<b>Biopsiezange mit Dorn / Biopsy forceps with thorn</b>					
	28-064-000	28-064-101				
	26-064-000	26-064-101				
	<b>BLAKESLY, Biopsiezange / BLAKESLY, Biopsy forceps</b>					
	28-081-000	28-081-101				
	26-081-000	26-081-101				
	<b>Biopsiestanze / Biopsy punch</b>					
	28-060-000	28-060-101				
	26-060-000	26-060-101				
	<b>Biopsiestanze / Biopsy punch</b>					
	28-062-000	28-062-101				
	26-062-000	26-062-101				
	<b>Fasszange / Grasping forceps</b>					
	28-065-000		28-065-103			
	26-065-000		26-065-103			
	<b>Fasszange mit Fenster / Grasping forceps fenestrated</b>					
	28-079-000		28-079-103			
	26-079-000		26-079-103			















Außenrohr / Outer Tube 330 mm 28-000-100 5mm  
 430 mm 26-000-100 5mm



	Länge Working length	Griff allein Handle 28-000-001	Griff allein Handle 28-000-003	Griff allein Handle 28-000-005	Griff allein Handle 28-000-007	Griff allein Handle 28-000-047
	330 mm					
	430 mm					
	Einsatz Nr. Insert no.	Komplettes Instrument 5 mm Complete Instrument 5 mm				
	Fasszange, feines Modell / Grasping forceps, delicate pattern					
	28-066-000		28-066-103			
	26-066-000		26-066-103			
	Fasszange, kräftiges Maul / Grasping forceps, heavy pattern					
	28-078-000		28-078-103			
	26-078-000		26-078-103			
	Fasszange / Grasping forceps					
	28-068-000		28-068-103			
	26-068-000		26-068-103			
	Fasszange, spitz / Grasping forceps, pointed					
	28-069-000		28-069-103			
	26-069-000		26-069-103			
	Fasszange / Grasping forceps					
	28-075-000		28-075-103			
	26-075-000		26-075-103			
	Dissektionszange, atraumatisch / Dissecting forceps, atraumatic serration					
	28-070-000	28-070-101				
	26-070-000	26-070-101				
	MARYLAND, Dissektionszange, gebogen / MARYLAND, Dissecting forceps, curved					
	28-072-000	28-072-101				
	26-072-000	26-072-101				
	Dissektionszange, gebogen 45° / Dissecting forceps, curved 45°					
	28-246-000	28-246-101		28-246-105		
	26-246-000	26-246-101		26-246-105		
	Dissektionszange, gebogen 90° / Dissecting forceps, curved 90°					
	28-247-000	28-247-101		28-247-105		















Außenrohr / Outer Tube 330 mm 28-000-100 5mm  
430 mm 26-000-100 5mm



	Länge Working length	Griff allein Handle 28-000-001	Griff allein Handle 28-000-003	Griff allein Handle 28-000-005	Griff allein Handle 28-000-007	Griff allein Handle 28-000-047
	330 mm					
	430 mm					
	Einsatz Nr. Insert no.	Komplettes Instrument 5 mm Complete Instrument 5 mm				
	<b>Fasszange, atraumatisch, De Bakey, mit Hartmetall-Einlage /</b> Grasping forceps, atraumatic, De Bakey, with tungsten carbide					
	28-240-000		28-240-103		28-240-107	
	<b>Fasszange, atraumatisch, De Bakey /</b> Grasping forceps, atraumatic, De Bakey					
	28-242-000		28-242-103		28-242-107	
	26-242-000		26-242-103		26-242-107	
	<b>Fasszange /</b> Grasping forceps					
	28-077-000		28-077-103			
	26-077-000		26-077-103			
	<b>Fasszange 2x3 Zähne /</b> Grasping forceps 2x3 teeth					
	28-076-000		28-076-103			
	26-076-000		26-076-103			
	<b>Krallengreifer 2x3 Zähne /</b> Claw forceps 2x3 teeth					
	28-083-000		28-083-103		28-083-107	
	<b>DORSEY, Fasszange /</b> DORSEY, Grasping forceps					
	28-249-000		28-249-103		28-249-107	
	<b>Fasszange HI mit Hartmetall-Einlage /</b> Grasping forceps HI with tungsten carbide					
	28-286-000		28-286-103		28-286-107	
	26-286-000		26-286-103		26-286-107	
	<b>ALLIS, Fasszange /</b> ALLIS, Grasping forceps					
	28-105-000		28-105-103		28-105-107	
	<b>ALLIS, Fasszange, atraumatisch, De Bakey /</b> ALLIS, Grasping forceps, atraumatic, De Bakey					
	28-111-000		28-111-103		28-111-107	













Außenrohr / Outer Tube 330 mm 28-000-100 5mm  
430 mm 26-000-100 5mm



	Länge Working length	Griff allein Handle 28-000-001	Griff allein Handle 28-000-003	Griff allein Handle 28-000-005	Griff allein Handle 28-000-007	Griff allein Handle 28-000-047
	330 mm					
	430 mm					
	Einsatz Nr. Insert no.	Komplettes Instrument 5 mm Complete Instrument 5 mm				
	<b>ALLIS, Fasszange, atraumatisch, mit Hartmetall-Einlage / ALLIS, Grasping forceps, atraumatic, with tungsten carbide</b>					
	28-117-000		28-117-103		28-117-107	
	<b>KOCHER, Fasszange, atraumatisch, De Bakey / KOCHER, Grasping forceps, atraumatic, De Bakey</b>					
	28-171-000		28-171-103		28-171-107	
	<b>Dissektionszange, gebogen / Dissecting forceps, curved</b>					
	28-073-000	28-073-101				
	<b>Dissektions Zange 90° gebogen, für Verwendung mit 12,5 mm Trokarhülse / Dissecting forceps 90° curved, using with 12,5 mm trocar sleeve</b>					
	28-067-000	28-067-101				
	<b>Endo-Klemme, einfach DeBakey mit Schließschutz / Endo-Forceps with single DeBakey, closing protection</b>					
	28-198-000		28-198-103		28-198-107	
	<b>Endo-Lungentastzange / Endo-Lung Palpation forceps</b>					
	28-233-000	28-233-101		28-233-105		
	<b>Nadelhalter mit Hartmetall-Einlagen 8 mm / Needle holder with tungsten carbide inserts 8mm</b>					
	28-201-000					28-201-147
	<b>Nadelhalter mit Hartmetall-Einlagen 10 mm / Needle holder with tungsten carbide inserts 10mm</b>					
	28-203-000					28-203-147
	<b>Nahtfasszange, U-förmiges Maul / Suture fixation forceps, U-shaped jaws</b>					
	28-248-000					28-248-147











Außenrohr / Outer Tube 330 mm 28-000-100 5mm



	Länge Working length	Griff allein Handle 28-000-002	Griff allein Handle 28-000-004	Griff allein Handle 28-000-006	Griff allein Handle 28-000-008	
	330 mm					
	Einsatz Nr. Insert no.	Komplettes Instrument 10 mm Complete Instrument 10 mm				
	<b>Große Operationsschere / Operating scissors, large</b>					
	28-084-000	28-084-202		28-084-206		
	<b>Große Löffelzange / Spoon forceps, large</b>					
	28-180-000		28-180-204		28-180-208	
	<b>Krallengreifer 2x3 Zähne / Claw forceps 2x3 teeth</b>					
	28-179-000		28-179-204		28-179-208	
	<b>Fasszange, kräftiges Modell / Grasping forceps, heavy pattern</b>					
	28-225-000		28-225-204		28-225-208	
	<b>MARYLAND, Dissektionszange, gebogen / MARYLAND, Dissecting forceps, curved</b>					
	28-074-000	28-074-202				
	<b>ALLIS, Fasszange / ALLIS, Grasping forceps</b>					
	28-101-000		28-101-204		28-101-208	
	<b>ALLIS, Fasszange, atraumatisch, DeBakey / ALLIS, Grasping forceps, atraumatic, DeBakey</b>					
	28-108-000		28-108-204		28-108-208	
	<b>ALLIS, Fasszange, atraumatisch, mit Hartmetall-Einlage / ALLIS, Grasping forceps, atraumatic, with tungsten carbide</b>					
	28-214-000		28-214-204		28-214-208	
	<b>BABCOCK, Fasszange / BABCOCK, Grasping forceps</b>					
	28-120-000		28-120-204		28-120-208	











Außenrohr / Outer Tube 330 mm 28-000-200 10 mm



	Länge Working length	Griff allein Handle 28-000-002	Griff allein Handle 28-000-004	Griff allein Handle 28-000-006	Griff allein Handle 28-000-008		
	330 mm						
	Einsatz Nr. Insert no.	Komplettes Instrument 10 mm Complete Instrument 10 mm					
	<b>BABCOCK, Fasszange, atraumatisch, DeBakey / BABCOCK, Grasping forceps, atraumatic, DeBakey</b>						
	28-123-000		28-123-204		28-123-208		
	<b>BABCOCK, Fasszange, atraumatisch, mit Hartmetall-Einlagen / BABCOCK, Grasping forceps, atraumatic, with tungsten carbide</b>						
	28-220-000		28-220-204		28-220-208		
	<b>DUVAL, Fasszange / DUVAL, Grasping forceps</b>						
	28-176-000		28-176-204		28-176-208		
	<b>COLLIN, Fasszange, atraumatisch/ COLLIN, Grasping forceps, atraumatic</b>						
	28-181-000		28-181-204		28-181-208		
	<b>COLLIN, Fasszange, atraumatisch, mit Hartmetall-Einlagen / COLLIN, Grasping forceps, atraumatic, with tungsten carbide inserts</b>						
	28-074-000	28-074-202					
	<b>Dissektions-Fasszange, atraumatisch, DeBakey / Dissecting-Grasping forceps, atraumatic, DeBakey</b>						
	28-080-000	28-080-202					

Außenrohr / Outer Tube 330 mm 28-000-200 10 mm



	Maullänge / Jaw length	Länge Working length	Griff allein Handle 28-000-002	Griff allein Handle 28-000-004	Griff allein Handle 28-000-006	Griff allein Handle 28-000-008
	Durchmesser Diameter	330 mm				
		Einsatz Nr. Insert no.	Komplettes Instrument 10 mm Complete Instrument 10 mm			
		KOCHER, Fasszange, atraumatisch / KOCHER, Grasping forceps, atraumatic				
	30 MM / 10 MM	28-126-000		28-126-204		28-126-208
	40 MM / 10 MM	28-129-000		28-129-204		28-129-208
	50 MM / 10 MM	28-132-000		28-132-204		28-132-208
	60 MM / 10 MM	28-135-000		28-135-204		28-135-208
		KOCHER, Fasszange, atraumatisch, einfache DeBakey / KOCHER, Grasping forceps, atraumatic, single De Bakey				
	30 MM / 10 MM	28-141-000		28-141-204		28-141-208
	40 MM / 10 MM	28-144-000		28-144-204		28-144-208
	50 MM / 10 MM	28-147-000		28-147-204		28-147-208
	60 MM / 10 MM	28-150-000		28-150-204		28-150-208
		KOCHER, Fasszange, atraumatisch, doppel De Bakey / KOCHER, Grasping forceps, atraumatic, double De Bakey				
	30 MM / 10 MM	28-156-000		28-156-204		28-156-208
	40 MM / 10 MM	28-159-000		28-159-204		28-159-208
	50 MM / 10 MM	28-162-000		28-162-204		28-162-208
	60 MM / 10 MM	28-165-000		28-165-204		28-165-208
		Endo-Klemme, einfach DeBakey mit Schließschutz / Endo-Forceps with single DeBakey, closing protection				
	40 MM / 10 MM	28-195-000		28-195-204		28-195-208
	50 MM / 10 MM	28-196-000		28-196-204		28-196-208
	60 MM / 10 MM	28-197-000		28-197-204		28-197-208
		Endo-Klemme, doppel DeBakey mit Schließschutz / Endo-Forceps with double DeBakey, closing protection				
	40 MM / 10 MM	28-191-000		28-191-204		28-191-208
	50 MM / 10 MM	28-192-000		28-192-204		28-192-208
	60 MM / 10 MM	28-193-000		28-193-204		28-193-208
		Endo-Lungentastzange / Endo-Lung Palpation forceps				
	40 MM / 10 MM	28-230-000	28-230-202		28-230-206	
	50 MM / 10 MM	28-231-000	28-231-202		28-231-206	
	60 MM / 10 MM	28-232-000	28-232-202		28-232-206	

Außenrohr / Outer Tube 330 mm 28-000-200 10 mm



Die guten Resultate der offenen Abdominalchirurgie können auf herkömmliche Weise kaum noch verbessert werden. Durch den Einsatz moderner videoendoskopischer Technik und entsprechenden Instrumenten läßt sich das Trauma des operativen Zugangs jedoch erheblich reduzieren. Kleine Einstiche ersetzen den Bauchschnitt. Daraus ergeben sich die Vorteile der minimal-invasiven Chirurgie.

Mit einer Reihe neuentwickelter Instrumente möchte REMA einen aktuellen Beitrag zur laparoskopischen OP-Technik leisten.

Zur übersichtlichen Einstellung des OP-Situs bei laparoskopischen Operationen bietet Ihnen REMA nun das ideal abgestimmte Instrumentarium, entwickelt nach den hundertfach bewährten Vorbildern aus der klassischen Abdominalchirurgie.

### Das neue REMA Endo-Haken-System

Bei dem von REMA neu entwickeltem Endo-Haken-System handelt es sich um ein stabförmiges Instrument mit 5 mm und 10 mm Durchmesser an dessen vorderen Ende ein Endo-Haken befestigt ist. Am oberen Ende des Instrumentes ist ein Handgriff mit einer Betätigungsvorrichtung angebracht, die ein stufenloses Aufrichten des jeweiligen Hakens, von 0 bis 90 Grad, erlaubt. So ist es möglich, mit Hilfe eines entsprechenden REMA-Endo-Hakens, die gleichen Nutzeffekte zu erzielen, wie mit Haken in der klassischen Abdominalchirurgie.

The good results of open abdominal surgery can hardly be improved upon using conventional techniques. Through the application of modern video-endoscopic technology and appropriate instruments, however, the trauma of operative access can be substantially reduced. Small punctures replace abdominal sections. The advantages of minimal invasive surgery are the result.

With a number of new developed instruments REMA would like to make an up-to-date contribution to laparoscopic operating techniques.

For neat preparation of the operation situs during laparoscopic operations, REMA now offers you the ideal balanced set of instruments developed in accordance with hundreds of tried and tested examples from classic abdominal surgery.

### The new REMA Endo Hook System

The Endo Hook System new developed by REMA is a rod-shaped instrument having a diameter of 5 mm and 10 mm and on whose front end an Endo hook is fixed. At the top end of the instrument a handle with an operating mechanism is mounted, allowing for infinitely variable adjustment of the respective hook, from 0 to 90 degrees. Thus, with the help of an appropriate REMA Endo hook, it is possible to achieve the same beneficial effects as with hooks used in classic abdominal surgery.

**INSTRUMENT IN MONTIERTEM ZUSTAND**

**ASSEMBLED INSTRUMENT**



**INSTRUMENT IN DEMONTIERTEM ZUSTAND**

**DISASSEMBLED INSTRUMENT**











**Instrumenten-Einsatz**  
Insert, with instrument tip



**Handgriff**  
Handle







**Außenrohr mit Überwurfmutter**  
Outer tube with screw cap

	Maullänge / Jaw length	Länge Working length	Griff allein Handle 28-000-059	Griff allein Handle 28-000-060		
	Durchmesser Diameter	330 mm				
		Einsatz Nr. Insert no.	Komplettes Instrument Complete Instrument			
	Endo-Haken nach Kocher-Langenbeck / Endo-Retractor Kocher-Langenbeck					
	30 MM / 5 MM	29-001-000	29-001-159			
	40 MM / 5 MM	29-002-000	29-002-159			
	50 MM / 5 MM	29-003-000	29-003-159			
	30 MM / 10 MM	29-011-000		29-011-260		
	40 MM / 10 MM	29-012-000		29-012-260		
	50 MM / 10 MM	29-013-000		29-013-260		
	Endo-Haken nach Cushing / Endo-Retractor Cushing					
	30 MM / 10 MM	29-015-000		29-015-260		
	40 MM / 10 MM	29-016-000		29-016-260		
	50 MM / 10 MM	29-017-000		29-017-260		
	Endo-Haken fächerförmig / Endo-Retractor fan-shaped					
	50 MM / 5 MM	29-021-000	29-021-159			
	60 MM / 5 MM	29-022-000	29-022-159			
	50 MM / 10 MM	29-023-000		29-023-260		
	60 MM / 10 MM	29-024-000		29-024-260		
	Endo-Ösophagus-Haken/Dissektor / Endo-Esophageal-Retractor/Dissector					
	35 MM / 5 MM	29-030-000	29-030-159			
	35 MM / 10 MM	29-031-000		29-031-260		
	Endo-Ösophagus-Haken/Dissektor / Endo-Esophageal-Retractor/Dissector					
	35 MM / 10 MM	29-032-000		29-032-260		
	Endo-Laparolifter (in Verbindung mit CO2 Insufflation) / Endo-Laparolifter (in conjunction with CO2 insufflation)					
	40 MM / 10 MM	29-052-000		29-052-260		

Außenrohr / Outer Tube 330 mm 28-000-200 10 mm  
 330 mm 28-000-100 5 mm



	Maullänge / Jaw length	Länge Working length	Griff allein Handle 28-000-060			
	Durchmesser Diameter	330 mm				
		Einsatz Nr. Insert no.	Komplettes Instrument Complete Instrument			
	Endo-Exzentrischer "Y" Retraktor / Endo-Eccentric "Y" Retractor					
	40-60 MM / 10 MM	28-600-000 R	28-600-260 R			
	Endo-Exzentrischer "Y" Retraktor / Endo-Eccentric "Y" Retractor					
	60-40 MM / 10 MM	28-600-000 L	28-600-260 L			
	Endo-Exzentrischer "Y" Retraktor / Endo-Eccentric "Y" Retractor					
	60-60 MM / 10 MM	28-600-000 S	28-600-260 S			

Außenrohr / Outer Tube 330 mm 28-000-200 10 mm



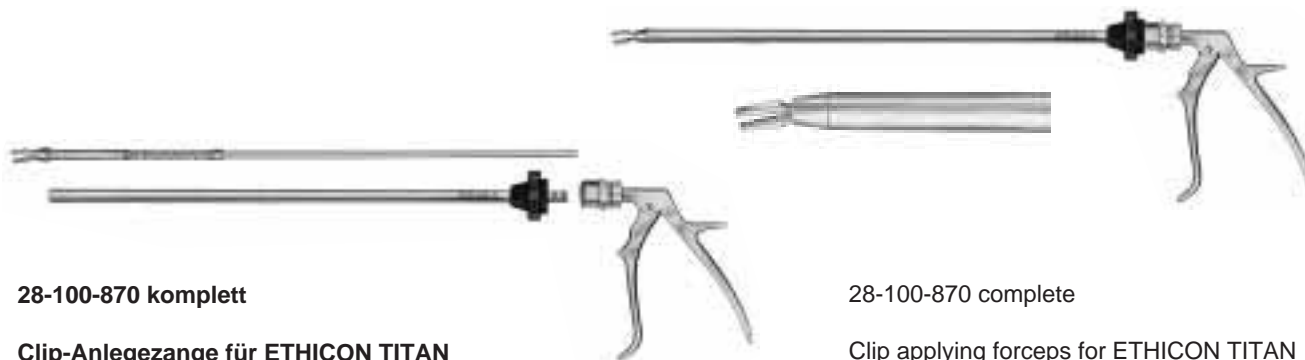

**28-100-870 komplett**

**Clip-Anlegezange für ETHICON TITAN LIGACLIP (mittelgroß)**  
 bestehend aus:  
 28-100-000 Zangen-Einsatz  
 28-000-800 Außenrohr ø 10 mm  
 28-000-070 Handgriff

**Weitere Zangen-Einsätze auf Anfrage**

**28-100-870 complete**

**Clip applying forceps for ETHICON TITAN LIGA CLIP (medium-large)**  
 consisting of:  
 28-100-000 Insert, forceps  
 28-000-800 Outer tube ø 10 mm  
 28-000-070 Handle

**Further forceps Inserts, on request**



**25-00500**  
**Applikator für Endo-Ligatur, ø 5 mm**

**25-00500**  
**Applicator for endo-ligature, ø 5 mm**



**25-00501**  
**Knotenschieber, ø 5 mm**

**25-00501**  
**Knot-sliding instrument, ø 5 mm**



**25-00502**  
**Knotenschieber für extrakorporale Knotung, ø 5 mm**  
**(mit Applikator 25-00500 verwendbar)**

**25-00502**  
**Knot guide for extracorporeal knotting, ø 5 mm**  
**(only useable with applicator 25-00500)**



**25-00503**  
**Knotenführer für extrakorporale Knotung, ø 5 mm**  
**(mit Applikator 25-00500 verwendbar)**

**25-00503**  
**Knot guide for extracorporeal knotting, ø 5 mm**  
**(only useable with applicator 25-00500)**

**Endoskop- und Instrumentenhalterung**  
**komplett autoklavierbar**  
**28-700-000**

- bestehend aus:
- REMA-Gelenkstativ #3800-40 (400 mm) mit einem Griff fixiert.
  - Optikhalterung ø 10 mm
  - Schraubsockel für Schienen 25x10 und 35x8 mm
  - Säule 300 mm, höhenverstellbar



**Endoscope and Instrument Holder**  
**fully autoclavable**  
**28-700-000**

- components:
- REMA Articulating post # 3800-40 (400 mm) fixed with the handle
  - Endoscope and Instrument Holder ø 10 mm
  - Thread base on rails 25x10 and 35x8 mm
  - Support 300 mm, adjustment of height

**Reinigungsbürste, 500 mm Länge****24-00011** für Außenrohre  $\varnothing$  5 mm isoliert/Metall  
und Außenrohre  $\varnothing$  10 mm isoliert**24-00012** für Außenrohre  $\varnothing$  10 mm Metall**Cleaning Brush, 500 mm length****24-00011** for Outer tube  $\varnothing$  5 mm insulated/metal  
and Outer tube  $\varnothing$  10 mm insulated**24-00012** for Outer tube  $\varnothing$  10 mm metal**Instrumentenöl P-102**  
**24-00010** 50 ml**Instrument Oil P-102**  
**24-00010** 50 ml

# Handgriffe Handles

**Handgriffe für dreh- und zerlegbare  
5 mm und 10 mm Instrumente:**  
Handles for rotating and detachable  
5 mm and 10 mm Instruments:



**28-000-001**     $\varnothing$  5 mm  
**28-000-002**     $\varnothing$  10 mm  
mit HF-Anschluß  
ohne Sperre  
with HF-connector  
without ratchet



**28-000-003**     $\varnothing$  5 mm  
**28-000-004**     $\varnothing$  10 mm  
mit HF-Anschluß  
mit Sperre  
with HF-connector  
with ratchet



**28-000-005**     $\varnothing$  5 mm  
**28-000-006**     $\varnothing$  10 mm  
ohne Sperre  
without ratchet



**28-000-007**     $\varnothing$  5 mm  
**28-000-008**     $\varnothing$  10 mm  
mit Sperre  
with ratchet



**28-000-009**     $\varnothing$  5 mm  
**28-000-010**     $\varnothing$  10 mm  
Metall Rückholfeder  
metal spring action

**Handgriffe für zerlegbare  
5 mm und 10 mm Instrumente:**  
Handles for detachable  
5 mm and 10 mm Instruments:



**28-000-021**     $\varnothing$  5 mm  
**28-000-022**     $\varnothing$  10 mm  
mit HF-Anschluß  
ohne Sperre  
with HF-connector  
without ratchet



**28-000-023**     $\varnothing$  5 mm  
**28-000-024**     $\varnothing$  10 mm  
mit HF-Anschluß  
mit Sperre  
with HF-connector  
with ratchet



**28-000-025**     $\varnothing$  5 mm  
**28-000-026**     $\varnothing$  10 mm  
ohne Sperre  
without ratchet



**28-000-027**     $\varnothing$  5 mm  
**28-000-028**     $\varnothing$  10 mm  
mit Sperre  
with ratchet



**28-000-029**     $\varnothing$  5 mm  
**28-000-030**     $\varnothing$  10 mm  
Metall Rückholfeder  
metal spring action



**Handgriffe für dreh- und zerlegbare 5 mm und 10 mm Instrumente:**  
Handles for rotating and detachable 5 mm and 10 mm Instruments:



**28-000-041**     $\varnothing$  5 mm  
**28-000-042**     $\varnothing$  10 mm  
**ohne Sperre**  
without ratchet

**28-000-043**  $\varnothing$     5 mm  
**28-000-044**  $\varnothing$     10 mm  
**mit Sperre**  
with ratchet

**Griffe / Handles**

**Handgriffe für zerlegbare 5 mm und 10 mm Instrumente:**  
Handles for detachable 5 mm and 10 mm Instruments:



**28-000-045**     $\varnothing$  5 mm  
**28-000-046**     $\varnothing$  10 mm  
**ohne Sperre**  
without ratchet

**28-000-047**     $\varnothing$  5 mm  
**28-000-048**     $\varnothing$  10 mm  
**mit Sperre**  
with ratchet



**28-000-059**     $\varnothing$  5 mm  
**28-000-060**     $\varnothing$  10 mm

**Ersatzteile**  
Spare Parts



**28-000-100**     $\varnothing$  5 mm Außenrohr isoliert / Outer tube insulated  
**28-000-300**     $\varnothing$  5 mm Außenrohr Metall / Outer tube metal  
**Außenrohr mit Überwurfmutter für 5 mm Instrumente**  
Outer tube with screw cap for 5 mm Instruments



**28-000-200**     $\varnothing$  10 mm Außenrohr isoliert / Outer tube insulated  
**28-000-400**     $\varnothing$  10 mm Außenrohr Metall / Outer tube metal  
**Außenrohr mit Überwurfmutter für 10 mm Instrumente**  
Outer tube with screw cap for 10 mm Instruments



**28-000-500**  
**Überwurfmutter für 5 mm Instrumente**  
Screw cap for 5 mm Instruments



**28-000-600**  
**Überwurfmutter für 10 mm Instrumente**  
Screw cap for 10 mm Instruments

**INSTRUMENT IN MONTIERTEM ZUSTAND**

**ASSEMBLED INSTRUMENT**

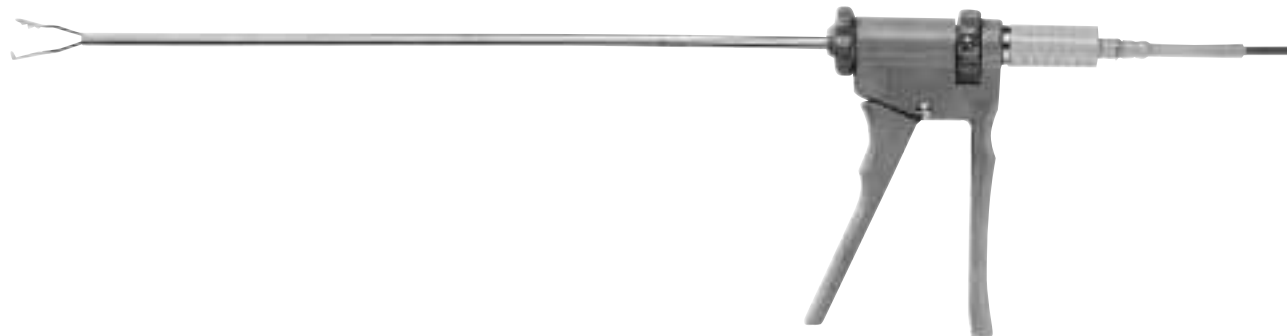

**INSTRUMENT IN DEMONTIERTEM ZUSTAND**

**DISASSEMBLED INSTRUMENT**

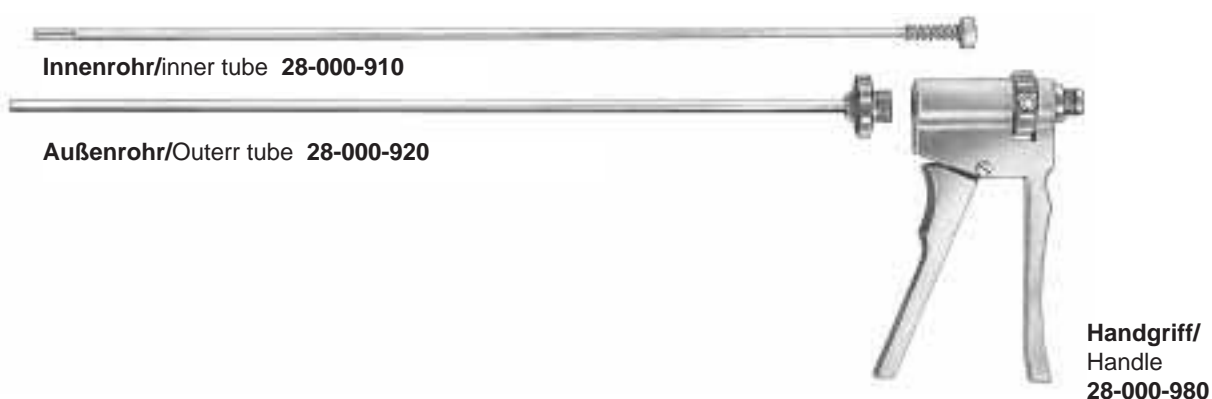

**Innenrohr/inner tube 28-000-910**

**Außenrohr/Outerr tube 28-000-920**

**Handgriff/  
Handle  
28-000-980**



**28-210-980 komplett**

**Bipolar Zange 1 mm, komplett  
bestehend aus:**

- 28-210-000 Zangen-Einsatz**
- 28-000-920 Außenrohr ø 5 mm**
- 28-000-910 Innenrohr**
- 28-000-980 Handgriff**

**28-210-980 complete**

**Bipolar Forceps 1 mm, complete,  
consisting of:**

- 28-210-000 Insert forceps**
- 28-000-920 Outer tube ø 5 mm**
- 28-000-910 Inner tube**
- 28-000-980 Handle**

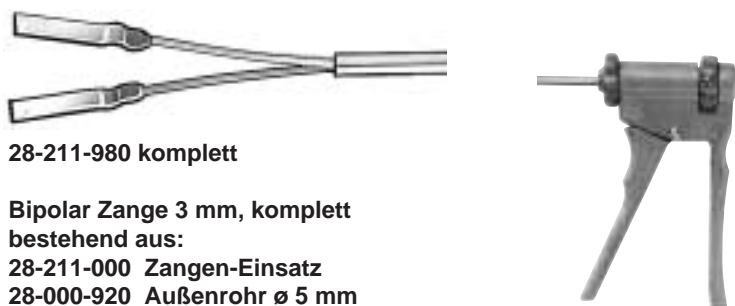

**28-211-980 komplett**

**Bipolar Zange 3 mm, komplett  
bestehend aus:**

- 28-211-000 Zangen-Einsatz**
- 28-000-920 Außenrohr ø 5 mm**
- 28-000-910 Innenrohr**
- 28-000-980 Handgriff**

**28-211-980 complete**

**Bipolar Forceps 3 mm, complete,  
consisting of:**

- 28-211-000 Insert forceps**
- 28-000-920 Outer tube ø 5 mm**
- 28-000-910 Inner tube**
- 28-000-980 Handle**

### INSTRUMENT IN MONTIERTEM ZUSTAND

### ASSEMBLED INSTRUMENT



28-00440 Adapter

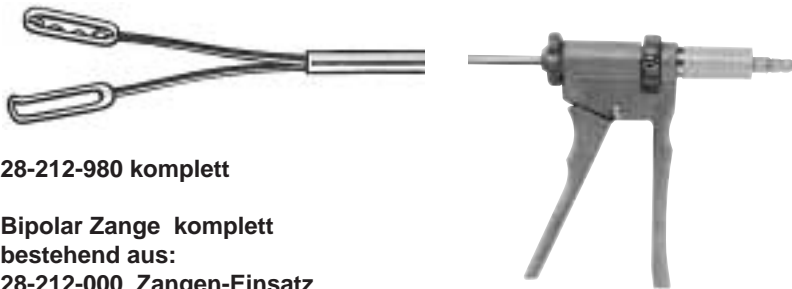

28-212-980 komplett

**Bipolar Zange komplett**

bestehend aus:

- 28-212-000 Zangen-Einsatz
- 28-000-920 Außenrohr ø 5 mm
- 28-000-910 Innenrohr
- 28-000-980 Handgriff

28-212-980 complete

Bipolar Forceps complete,  
consisting of:

- 28-212-000 Insert forceps
- 28-000-920 Outer tube ø 5 mm
- 28-000-910 Inner tube
- 28-000-980 Handle

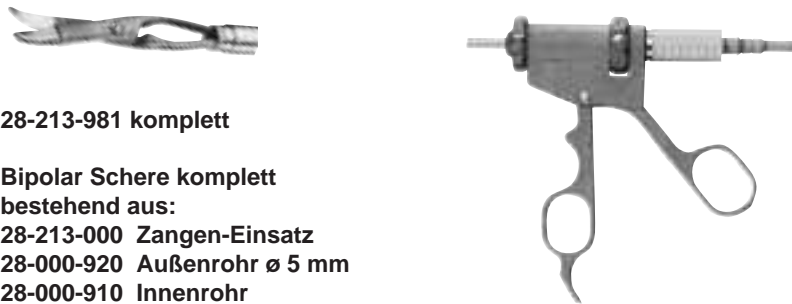

28-213-981 komplett

**Bipolar Schere komplett**

bestehend aus:

- 28-213-000 Zangen-Einsatz
- 28-000-920 Außenrohr ø 5 mm
- 28-000-910 Innenrohr
- 28-000-081 Handgriff

28-213-981 complete

Bipolar Scissors complete,  
consisting of:

- 28-213-000 Insert forceps
- 28-000-920 Outer tube ø 5 mm
- 28-000-910 Inner tube
- 28-000-081 Handle



28-00400  
Stecker für Valleylab-Geräte  
Valleylab-plug



28-00420  
Stecker für Erbe-Geräte  
Erbe-plug



28-00410  
Stecker für Codmann-Geräte  
Codman-plug



28-00430  
Stecker für Martin/Berchtold-Geräte  
Martin/Berchtold-plug



**Darmgreifer**  
Bowel Forceps

25-00200



**Atraumatische Faßzange**  
Atraumatic Grasping Forceps

25-00201



**Eileiter Faßzange, t-förmig**  
Fimbrial Holding Forceps, t-pattern

25-00202



**Eileiter Faßzange, quadratisch**  
Fimbrial Holding Forceps, square pattern

25-00203



**Eileiter Faßzange, ring-förmig**  
Fimbrial Holding Forceps, ring-pattern

25-00204



**Tupfer- Faßzange**  
Swab Grasper

25-00205



**Alle Instrumente auch in 33 cm Länge erhältlich, siehe Kapitel 1, ab Seite 17**

*All Instruments also in the length of 33 cm available, see chapter 1, page 17*



26-051-101  
 H  
 26-051-000 S -E  
 26-000-100 A 5  
 28-000-001 H HF-A



26-051-101 complete  
 Hook scissors, straight, consisting of:  
 26-051-000 Insert, scissors  
 26-000-100 Outer tube, ø 5 mm  
 28-000-001 Handle with HF-connector



MET ENBAUM  
 26-056-101  
 P  
 26-056-000 S -E  
 26-000-100 A 5  
 28-000-001 H HF-A



METZENBAUM  
 26-056-101 complete  
 Dissecting scissors, curved, consisting of:  
 26-056-000 Insert, scissors  
 26-000-100 Outer tube, ø 5 mm  
 28-000-001 Handle with HF-connector



26-064-101  
 B D  
 26-064-000 B -E  
 26-000-100 A 5  
 28-000-001 H HF-A



26-064-101 complete  
 Biopsy forceps with thorn, consisting of:  
 26-064-000 Insert, biopsy forceps  
 26-000-100 Outer tube, ø 5 mm  
 28-000-001 Handle with HF-connector



BLAKESL  
 26-081-101  
 B  
 26-081-000 B -E  
 26-000-100 A 5  
 28-000-001 H HF-A



BLAKESLY  
 26-081-101 complete  
 Biopsy forceps, consisting of:  
 26-081-000 Insert, biopsy forceps  
 26-000-100 Outer tube, ø 5 mm  
 28-000-001 Handle with HF-connector



26-060-101  
 B  
 26-060-000 B -E  
 26-000-100 A 5  
 28-000-001 H HF-A



26-060-101 complete  
 Biopsy punch, consisting of:  
 26-060-000 Insert, biopsy punch  
 26-000-100 Outer tube, ø 5 mm  
 28-000-001 Handle with HF-connector

**Alle Instrumente auch in 33 cm Länge erhältlich, siehe Kapitel 1, ab Seite 17**

*All Instruments also in the length of 33 cm available, see chapter 1, page 17*



26-062-101

B  
 26-062-000 B -E  
 26-000-100 A 5  
 28-000-001 H HF-A



unipolar

26-062-101 complete

Biopsy punch, consisting of:  
 26-062-000 Insert, biopsy punch  
 26-000-100 Outer tube, ø 5 mm  
 28-000-001 Handle with HF-connector



26-065-103

F  
 26-065-000 F -E  
 26-000-100 A 5  
 28-000-003 H HF-A  
 S



unipolar

26-065-103 complete

Grasping forceps, consisting of:  
 26-065-000 Insert, grasping forceps  
 26-000-100 Outer tube, ø 5 mm  
 28-000-003 Handle with HF-connector and ratchet



26-078-103

F M  
 26-078-000 F -E  
 26-000-100 A 5  
 28-000-003 H HF-A  
 S



unipolar

26-078-103 complete

Grasping forceps, heavy pattern, consisting of:  
 26-078-000 Insert, grasping forceps  
 26-000-100 Outer tube, ø 5 mm  
 28-000-003 Handle with HF-connector and ratchet



26-242-107

F , D B  
 26-242-000 F -E  
 26-000-100 A 5  
 28-000-007 H S



26-242-107 complete

Grasping forceps, atraumatic, De Bakey, consisting of:  
 26-242-000 Insert, grasping forceps  
 26-000-100 Outer tube, ø 5 mm  
 28-000-007 Handle with ratchet



26-076-103

F 2 3  
 26-076-000 F -E  
 26-000-100 A 5  
 28-000-003 H HF-A  
 S



unipolar

26-076-103 complete

Grasping forceps 2 x 3 teeth, consisting of:  
 26-076-000 Insert, grasping forceps  
 26-000-100 Outer tube, ø 5 mm  
 28-000-003 Handle with HF-connector and ratchet



INSTRUMENT IN MONTIERTEM USTAND

ASSEMBLED INSTRUMENT



INSTRUMENT IN DEMONTIERTEM USTAND

DISASSEMBLED INSTRUMENT



26-210-980 komplett

Bipolar Zange 1 mm, komplett  
 bestehend aus:  
 26-210-000 Zangen-Einsatz  
 26-000-920 Außenrohr ø 5 mm  
 26-000-910 Innenrohr  
 28-000-980 Handgriff



26-210-980 complete

Bipolar Forceps 1 mm, complete,  
 consisting of:  
 26-210-000 Insert forceps  
 26-000-920 Outer tube ø 5 mm  
 26-000-910 Inner tube  
 28-000-980 Handle



26-211-980

B 3  
 :  
 26-211-000 -E  
 26-000-920 A 5  
 26-000-910 I  
 28-000-980 H



26-211-980 complete

Bipolar Forceps 3 mm, complete,  
 consisting of:  
 26-211-000 Insert forceps  
 26-000-920 Outer tube ø 5 mm  
 26-000-910 Inner tube  
 28-000-980 Handle

INSTRUMENT IN MONTIERTEM USTAND

ASSEMBLED INSTRUMENT



28-00400 A

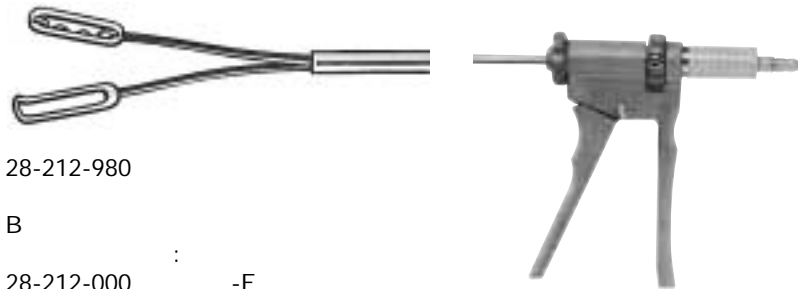

28-212-980

28-212-980 complete

- B
- 28-212-000 -E
- 28-000-920 A 5
- 28-000-910 I
- 28-000-980 H

- Bipolar Forceps complete, consisting of:
- 28-212-000 Insert forceps
- 28-000-920 Outer tube ø 5 mm
- 28-000-910 Inner tube
- 28-000-980 Handle

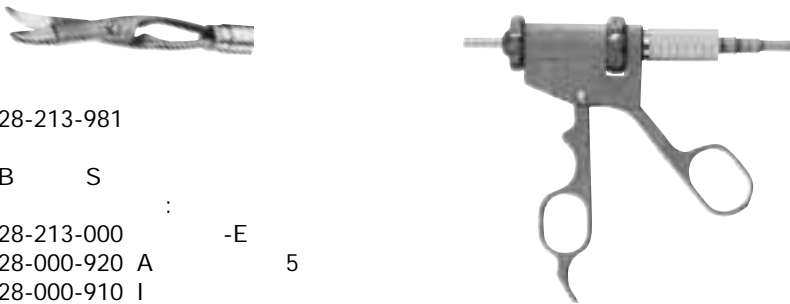

28-213-981

28-213-981 complete

- B S
- 28-213-000 -E
- 28-000-920 A 5
- 28-000-910 I
- 28-000-081 H

- Bipolar Scissors complete, consisting of:
- 28-213-000 Insert forceps
- 28-000-920 Outer tube ø 5 mm
- 28-000-910 Inner tube
- 28-000-081 Handle



28-00400 S V -G  
Valleylab-plug



28-00420 S E -G  
Erbe-plug



28-00410 S C -G  
Codman-plug



28-00430 S M /B -G  
Martin/Berchtold-plug